

calculated number of unpaired spins per nickel atom is 0.82.

8. **Properties of Intermediates with Composition near $Ba_2Ni_2O_5$.**—At 730° in oxygen at 730 mm. pressure the structure associated with $BaNiO_3$ changes to that associated with $Ba_2Ni_2O_5$ and the product obtained is black. It may be heated in oxygen to 1200° (where it melts) without further gross change in structure. These materials give negative tests for peroxide and liberate chlorine from dilute hydrochloric acid. The study described in Section 5 revealed no tendency toward higher stability of certain definite compositions.

All these intermediates have almost identical hexagonal unit cells with barium ions in an hexagonal close-packed

arrangement. The nickel and oxygen positions were not obtained from the powder pattern data. The calculated density of a product obtained at 850° is 6.40 g./cm.^3 , the formula $Ba_2Ni_2O_5$ being assumed.

The electrical resistivity of a pressed disc made from the 800° product was found to be $7 \times 10^8 \text{ ohm-cm.}$ It was an N-type conductor.

The magnetic susceptibility per g. of nickel at 300°K. , measured by F. Morin, was 1.24 and data obtained between 50 and 300°K. fit the Curie-Weiss law with $\Delta = 100^\circ\text{K.}$ The calculated number of unpaired spins per nickel atom is 0.97.

MURRAY HILL, N. J.

RECEIVED MAY 12, 1950

[CONTRIBUTION FROM STERLING CHEMISTRY LABORATORY, YALE UNIVERSITY]

A New Calorimetric Method^{1,2}

BY ANNE BUZZELL³ AND JULIAN M. STURTEVANT

An apparatus suitable for the measurement of the heat effects of slow chemical reactions in aqueous solutions is described. Twin calorimeters serve as a thermal balance to compare the chemical energy evolved or absorbed with automatically adjusted electrical energy, and analog computers are used to evaluate the electrical energy. The functioning of the apparatus is illustrated by determinations of the heat of the inactivation of pepsin.

Introduction

It has long been recognized that the twin calorimetric method first employed by Joule⁴ is particularly well-suited in principle to the observation of the heat effects accompanying slow processes. However, this method, with electrical compensation, has not been applied to slow chemical reactions largely because of the difficulty of integrating the varying electrical power required for compensation.

In the twin calorimetric method as applied to exothermic chemical processes, the chemical energy liberated in one calorimeter is duplicated electrically in the other. In the case of an endothermic process, sufficient electrical energy is introduced into the calorimeter in which the process takes place to prevent any temperature change. The two calorimeters can be made very similar in thermal properties. If they are supported within an "adiabatic" shield, the differential method of operation permits the uncertainty of any remaining calorimetric corrections to be reduced to a very low value.

We have employed electromechanical computers to overcome the problem of measuring the electrical compensation energy. In the present report

we discuss the general method employed and the instrumentation involved. It will be evident that different designs of the calorimeters themselves, devised for a variety of purposes, can be used with the instrumentation to be described.

Outline of Method

Figure 1 gives a simplified block diagram of the apparatus. Calorimeters A and B are each equipped with constant resistance electrical heaters H_A and H_B , and resistance thermometers T_A and T_B . The thermometers are in adjacent arms of a 25-cycle Wheatstone bridge, the output of which is proportional to the temperature difference between the calorimeters. The bridge output is amplified and detected, the detector output is continuously squared by a computer, and the squared voltage is integrated. The squarer also produces an unsquared voltage, E_4 , proportional to its input E_2 . This voltage is fed back to the heater of that calorimeter which requires electrical heat. The integrator output is proportional to the total electrical energy fed back.

If the ratio of the heater voltage, E_4 , to the bridge output voltage, E_1 , which produces it is sufficiently large, and if the over-all feedback system is stable (*i.e.*, does not oscillate), then the temperature difference between the calorimeters will always be held to small values. It is evident that under these circumstances there is no need to measure the actual temperature difference. The accuracy of the calorimetric observations is then determined, so far as the instrumentation is concerned, by the accuracy of the squaring and integrating computers. These are of a type to ensure reliability and stability of calibration.

As is always the case with feedback systems which include a thermal link, careful attention has to be paid to minimizing the thermal lag between heaters and thermometers in order to be able to employ a reasonably high sensitivity without oscillation of the system.

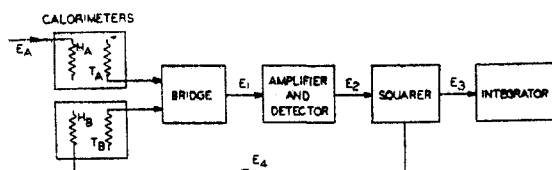

Fig. 1.—Simplified block diagram of apparatus.

(1) The apparatus described in this paper was developed in a program of calorimetric investigations of protein reactions aided by grants from the American Cancer Society on recommendation of the Committee on Growth of the National Research Council.

(2) Presented in part at the Meeting of the American Chemical Society, Chicago, September, 1950.

(3) Research fellow under grants from the American Cancer Society.

(4) J. P. Joule, *Mem. Proc. Manchester Lit. Phil. Soc.*, **2**, 559 (1845).

Description of Components

Thermometers and Heaters.—The calorimeter thermometers are 50-ohm windings of 0.4 by 0.025 mm. nickel ribbon wound on mica cards and pressed tightly around the outside of the tantalum calorimeter cans, which have a diameter of 3.2 cm. and a height of 5.4 cm. Each calorimeter is divided into equal halves by a tantalum disk with a hole in its center which may be closed by means of a rubber valve manipulated from outside the submarine vessel in which the whole calorimeter assembly is supported. Figure 2 shows one of the calorimeters assembled in its supporting frame and the other one opened to show the internal construction. The solutions between which reaction is to take place are introduced through small holes in each of the calorimeters, with the rubber valve closed. Stirring is accomplished by rocking the entire calorimetric assembly through an angle of 180° , and is ordinarily only used during the mixing of the reactants at the start of a reaction. The calorimeters are supported within two separate holes in an electrically heated aluminum jacket. The temperature of the jacket is measured by a 50-ohm nickel ribbon thermometer wound around its outside surface, and is automatically held closely equal to the mean of the calorimeter temperatures. The jacket is contained in a submarine in a thermostated⁵ water-bath.

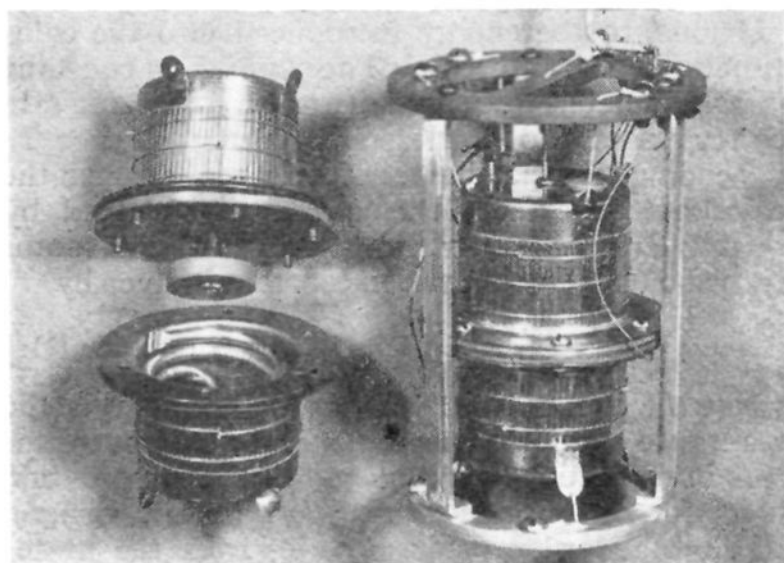

Fig. 2.—Photograph of calorimeters, with one partially dismantled to show internal construction.

Each calorimeter heater is composed of two 500-ohm windings of manganin wire contained in helices of 2.5 mm. platinum tubing inside the calorimeter cans. One of these helices can be seen in Fig. 2.

Thermometer Bridge.—The thermometers T_A and T_B constitute adjacent arms in one section of the double Wheatstone bridge illustrated in Fig. 3. R_1 and R_2 are the ratio arms (50 ohms) of this part of the bridge. The temperature information needed for the adiabatic control of the jacket is supplied by the other section of the bridge. The two sections of the bridge are balanced⁶ at thermal equilibrium by

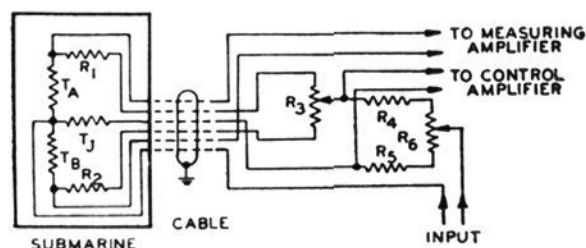

Fig. 3.—Schematic diagram of double Wheatstone bridge used in temperature measurements.

(5) J. M. Sturtevant, in A. Weissberger, "Physical Methods of Organic Chemistry," Vol. 1, part 1, 2nd edition, Interscience Publishers, Inc., New York, N. Y., 1949, p. 43.

(6) It is necessary to provide capacitive balancing of the bridge because of the various stray capacitances which are unavoidably present. The balancing capacitors have to be changed when the temperature at which measurements are made is changed more than a degree or so.

the 0.1-ohm slidewires R_3 and R_6 driven through 20:1 reduction drives.

The input to the bridge is 0.18 volt at about 25 c.p.s., and is monitored by a voltmeter which permits adjustment of the bridge supply to $\pm 2\%$. The dissipation in each calorimeter thermometer is 40 microwatts.

Measuring Amplifier and Detector.—The bridge output is transformer-coupled to an amplifier consisting of a single battery-powered stage followed by three stagger-tuned "twin-tee" feedback sections.⁷ The amplifier output is converted to direct current by a phase-sensitive detector with an output time constant of 0.5 sec. The total voltage gain from bridge output (r.m.s.) to detector output (d.c.) is about 10^9 , which in normal operation is reduced to 6.5×10^7 . With a bridge supply frequency well below 60 c.p.s., no trouble due to pick-up is encountered even at these high gains.

The noise level of the detector output corresponds to an input to the amplifier system of slightly less than 10^{-9} r.m.s. volt. The Johnson noise to be expected from a 50-ohm source in a band width defined by a single-section low-pass filter having a time constant of 0.5 sec. is about 5×10^{-10} r.m.s. volt, which indicates that the amplifier system introduces very little additional noise.

The calorimeter thermometer bridge output is approximately 135 microvolts per degree of temperature difference between the calorimeters. The amplifier noise level thus permits detection of temperature changes with a sensitivity of five micro-degrees, which corresponds to a resistance change of 1.5 micro-ohms. It is not surprising that some difficulties have been encountered in measuring temperature differences with this precision by means of resistance thermometers. It is obvious that all circuit connections must be carefully soldered, and that all the bridge resistors except the 0.1-ohm slidewires must be thermostated. More difficult to avoid are spurious resistance changes resulting from strain effects occurring during stirring or manipulation of the calorimeter valves. The card-wound form of calorimeter thermometer has given less trouble from strain effects than any other design we have tried, but even it appears occasionally to be subject to this weakness.

Squaring Computer and Integrator.—A schematic diagram of the squaring computer is given in Fig. 4. A voltage derived from the precision linear potentiometer R_1 , after division by the ratio $R_6/(R_5 + R_6)$, is compared with the detector output. Any difference between these voltages is converted⁸ to a.c., amplified,⁹ and fed to the servo motor¹⁰ which turns R_1 to reduce the difference nearly to zero. The output of the second potentiometer R_2 is then proportional to the square of the detector voltage if R_3 and R_4 are selected to make the loading of the potentiometers equal. The potentiometers, which are 3-turn Helipot of 0.05% linearity, are driven full scale in three seconds. The computer is accurate over its full range to within $\pm 0.1\%$ of full scale.

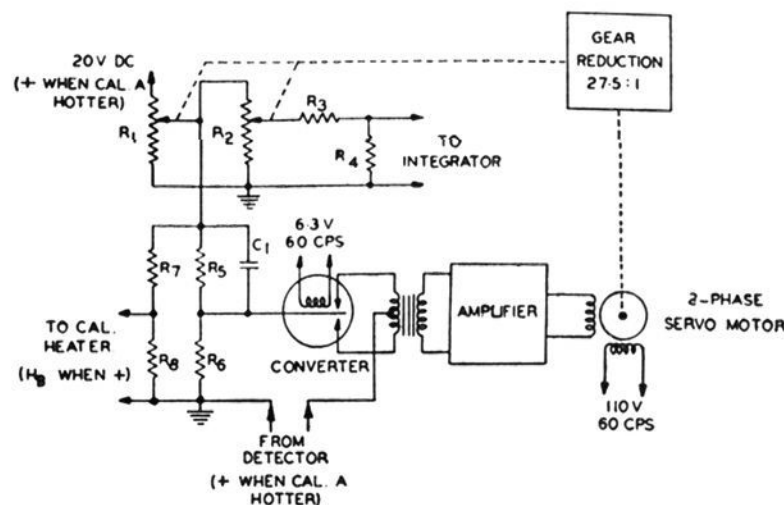

Fig. 4.—Diagram of analog computer used for squaring the detector output voltage.

(7) J. M. Sturtevant, *Rev. Sci. Instruments*, **18**, 124 (1947).

(8) By means of a synchronous reed converter obtainable from Brown Instrument Co., or Leeds and Northrup Co., both of Philadelphia, Pa.

(9) An amplifier suitable for this purpose is described in ref. 11.

(10) A low inertia two-phase control motor having a rating of 75 volts and 0.11 ampere, and obtainable from Diehl Manufacturing Co., FINDERNE, N. J., is suitable.

The power fed back to the calorimeter heater (the appropriate heater being selected by a manually operated switch) is derived from the output of R_1 by the divider R_7 - R_8 in order to avoid errors arising from the inability of the squarer to follow the rapid noise fluctuations present in the detector output, and from the fact that in some circumstances the detector output temporarily exceeds the value which drives the squarer full scale. In normal operation, $R_7 = 9.5K$ and $R_8 = 1K$, which gives a division ratio of 20:1 since the heater has a resistance of 1K.

The integrator, which is also an electromechanical computer of the analog type, has been described in a previous publication.¹¹ The speed of response of the integrator is ample to permit it to follow the squarer output fluctuations. The over-all accuracy of squaring and integrating is $\pm 0.2\%$ of full scale over a range of heating rates of more than 300:1.

The squarer-integrator combination constitutes a milliwatt-second meter the output of which can be read with a precision of better than 0.4 millijoule. Although it appears to be a somewhat complicated apparatus for accomplishing the desired result, it has been found to be very reliable in its operation, primarily because of the highly degenerate nature of its two components.

Automatic Recording of Data.—The integrator output is in the form of revolutions of a shaft which carries a cam to close a microswitch once each revolution. The microswitch controls a marking pen at the left-hand margin of a zero-center strip-chart recording potentiometer (Leeds and Northrup Speedomax, Type G, -10 to 0 to +10 millivolts). The integrator output shaft also drives a 360-degree linear potentiometer the output of which enables interpolation to 0.01 revolution. The potentiometer output is switched into the recorder for the last five seconds of each minute by a tuning-fork controlled clock. An accurate time scale is thus established. During the first 55 seconds of each minute a voltage proportional to the temperature difference between the calorimeters (the detector output divided by 1000) is recorded.

A full revolution of the integrator shaft corresponds to about 0.01 cal. Since the heat capacity of each calorimeter when full is about 30 cal. per deg., the heat data can be read with a precision corresponding to about three micro-degrees.

Figure 5 gives a typical record for a run. In this run phosphoric buffer was contained in one-half of Calorimeter B and pepsin solution at a lower pH in the other half. The buffer pH was chosen to give a pH after mixing of about 7.2, at which pH the inactivation of the pepsin proceeds at a convenient rate. In Fig. 5, the line near the center of the chart indicates the temperature difference between the calorimeters, the zero point being at the center. The irregularities in this line are mainly noise fluctuations. As mentioned above, the horizontal lines occurring at one-minute intervals show the output of the potentiometer driven by the integrator output shaft, one revolution of which is indicated by increase in the length of the horizontal lines from the

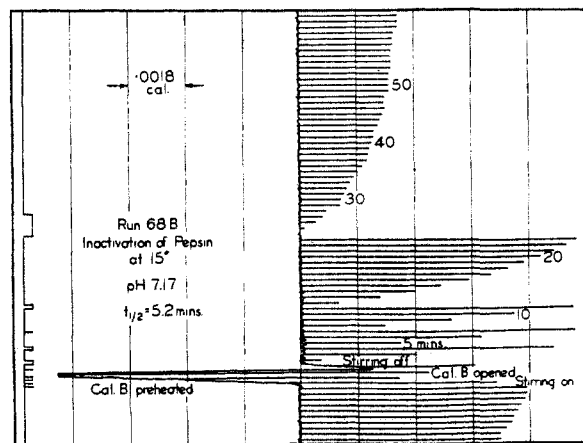

Fig. 5.—Record for a typical run, showing method of automatic recording of data.

(11) A. Buzzell and J. M. Sturtevant, *Rev. Sci. Instruments*, **19**, 6888 (1948).

center to the right-hand edge of the chart. Thus, during the interval between 11 and 23 minutes after starting the reaction the heat supplied electrically to Calorimeter B corresponded to one full revolution of the integrator shaft. The notches in the line at the left of the chart register full revolutions of the integrator shaft.

Since a large heat absorption was expected on mixing the reactants, Calorimeter B was preheated starting about 2.5 min. before initiating the reaction. The valve in Calorimeter B was opened at the indicated time; within two minutes the temperature difference had been restored to essentially zero, and the stirring was stopped. From this point on, the operation of the apparatus was fully automatic. Readings of the integrator output starting at the third minute after initiation of the reaction were used in the calculations as described below. The temperature record is useful in making adjustments and monitoring the run, but is not used in the calculations. The envelope of the integrator output lines, if unfolded, would be seen to be exponential in form, corresponding to the fact that as the reaction nears completion the rate of feedback of the compensating electrical energy decreases, eventually reaching zero.

Energy Measurements

Calibration.—The number of revolutions of the integrator shaft during an interval of time is proportional to the energy introduced into the calorimeter in that interval. The calibration constant is readily determined by noting the integrator rate corresponding to a measured current, I_A or I_B depending on which heater is energized, through the calorimeter heater. The current is obtained by setting R_1 (Fig. 4) manually, with the servo motor turned off. The calibration constant is given by

$$\rho_A = \frac{60 I_A^2 R_A}{\dot{r}_A} \times 10^{-6} \text{ joule per rev.} \quad (1)$$

where I_A is measured in milliamperes, R_A is the resistance of the heater, and \dot{r}_A is the integrator rate in revolutions per minute. A similar equation holds for ρ_B . For measuring I_A we use a General Radio standard resistor in series with the heater and a Rubicon portable potentiometer. This potentiometer is used for all accurate voltage measurements, and thus serves as the basic standard for our energy measurements. The heater resistance is evaluated from the ratio of the potential drop across the heater to that across the standard resistor.

The constants ρ_A and ρ_B can be determined in another way which gives a useful check on the functioning of the energy feedback system and also leads to a value for the ratio of the total effective heat capacities of the calorimeters plus their contents. In this method one calorimeter is heated by a known constant current while the other is heated by the automatically adjusted current from the squarer. Suppose B is automatically heated corresponding to an integrator rate of \dot{r}_B revolutions per minute (after correction for the drift rates observed before and after the heating period) when A is heated by I_A milliamperes. Since in such an experiment there is no net change in the temperature difference between the calorimeters, we have

$$\frac{60 I_A^2 R_A}{C_A} \times 10^{-6} = \frac{\rho_B \dot{r}_B}{C_B} \quad (2)$$

where C_A , C_B are the heat capacities of the calorimeters plus their contents. Similarly, when A is automatically heated

$$\frac{60 I_B^2 R_B}{C_B} \times 10^{-6} = \frac{\rho_A \dot{r}_A}{C_A} \quad (3)$$

If the calorimeters are heated by a current I with their heaters connected in series, a small temperature difference will in general result because of a small difference between C_A and C_B . Suppose the number of revolutions required to return this difference to zero divided by the number of minutes of series heating is \dot{r} , due allowance again being made for drift rates before and after the heating period. \dot{r} is taken as positive if B has to be heated at the end of the series heating period, that is, if $C_A < C_B$. Then

$$\frac{60I^2R_B}{C_B} \times 10^{-6} + \frac{\rho_B \dot{r}}{C_B} = \frac{60I^2R_A}{C_A} \times 10^{-6} \quad (4)$$

The term involving \dot{r} is small since C_A is nearly equal to C_B , so that in it we can replace ρ_B by ρ_A and C_B by C_A . It then follows that

$$\rho_A = \frac{60R_A}{\frac{\dot{r}_A}{I_B^2} + \frac{\dot{r}}{I^2}} \times 10^{-6} \quad (5)$$

$$\rho_B = \frac{60R_B}{\frac{\dot{r}_B}{I_A^2} - \frac{\dot{r}}{I^2}} \times 10^{-6} \quad (6)$$

$$\frac{C_A}{C_B} = \frac{R_A}{R_B} \left(1 - \frac{2\dot{r}/I^2}{(\dot{r}_A/I_B^2) + (\dot{r}_B/I_A^2)} \right) \quad (7)$$

Measurement of Chemical Energy.—In the case of an endothermic reaction carried out in calorimeter A, an amount of electrical heat indicated by a number, $(r_A)_{\text{chem}}$, of revolutions must be introduced into A to compensate for the chemical energy absorbed. Obviously, the latter is given by the relation

$$q_A = \rho_A (r_A)_{\text{chem}} \quad (8)$$

If an exothermic reaction is run in A, and B is heated electrically, the corresponding relation is

$$q_A = \frac{C_A}{C_B} \rho_B (r_B)_{\text{chem}} \quad (9)$$

Errors in Feedback System

A finite temperature difference between the calorimeters is required in order to develop the electrical energy fed back to minimize the temperature difference. This is clearly visible in the early stages of the reaction illustrated in Fig. 5. Two sources of error in observations on rate processes originate in this effect. One of these is due to heat exchange between the calorimeters (actually between each calorimeter and the jacket). The half-time of this heat exchange is slightly over 30 minutes when the calorimeters are full. Even during rapid reactions the temperature difference rarely exceeds 20 micro-degrees. This difference would result in an apparent heat transfer of 60 microjoules per minute, which is considered to be negligible.

A second source of error results from the fact that at any instant the integrated heat is too small by the amount required to return the temperature difference to zero. With the maximum sensitivity which can be employed with our equipment without serious instability, the error in the integrator output, δr rev., corresponding to a heating rate of \dot{r} rev. per min. is given by

$$\delta r \approx 0.13 \dot{r}^{1/2} \quad (10)$$

It can be shown that for a first order reaction the

corresponding fractional errors in the rate constant and heat of reaction are approximately

$$-\frac{\delta k}{k} \approx \frac{1}{2} \frac{\delta(\Delta H)}{(\Delta H)} \approx \frac{0.13k^{1/2}}{2(r_\infty - r_0)^{1/2}} \quad (11)$$

where k , the rate constant, is in reciprocal minutes, and $r_\infty - r_0$ is the number of revolutions corresponding to complete reaction. In the rather extreme case of a reaction having a half-time of three minutes and $r_\infty - r_0 = 5$, we thus have $-100(\delta k/k) = 1.4\%$.

In addition to these errors which result from the finite sensitivity of the feedback system, additional errors may arise from the thermal lags in the system. The magnitude of such errors will be dependent primarily on the design of the calorimeters, and whether or not stirring is continued during the reaction. If the viscosity of the reacting solution changes appreciably, stirring cannot be employed because the heat of stirring will vary during the reaction. In such a case, it is obvious that the heater should be distributed as uniformly as possible throughout the solution. This ideal situation is not very well approximated in our present design. Because of the complicated geometry involved, it is difficult to give a mathematical treatment of the errors to be expected, and we have therefore resorted to an experimental method. One can run duplicate experiments, one of which is carried out in the normal manner while the other is run without energy feedback. After correction of the observed temperature difference, in the latter case, for heat transfer as observed after the reaction is completed, the rate constant and total temperature change accompanying the reaction can be computed by the methods outlined in a previous publication.¹² The latter quantity can then be converted to energy units using the heat capacity of the calorimeter and its contents determined after the completion of the reaction. On the assumption that lag errors are negligible in the absence of energy compensation, it is found that the present design, with no stirring but with energy feedback, gives rate constants that are too low for reactions having half-times less than 5 minutes. However, the values of the heat of reaction determined with and without compensation agree satisfactorily even in the fastest reactions we have run (half-time about 2 minutes).

Calorimetric Errors.—The errors discussed in the previous section are characteristic of the continuous compensation mode of operation. The usual calorimetric errors will, of course, be present, though for the most part in reduced magnitude because of the small temperature difference between the calorimeters. It is in general necessary to determine the apparent "drift rate," though this may be kept to such a small value that it may be evaluated sufficiently accurately from observations made before the reaction is completely finished, a method of successive approximations being used in the calculations.

Illustration of Use of Apparatus.—The apparatus described in this paper has been used in a series of measurements of the heat absorption accompanying the loss of proteolytic activity of

(12) J. M. Sturtevant, *J. Phys. Chem.*, **45**, 127 (1941).

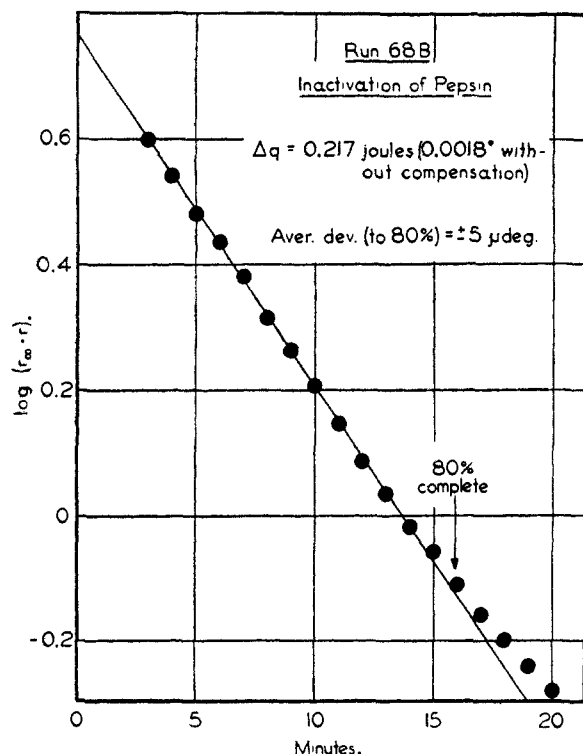

Fig. 6.—Logarithmic plot of the data of Fig. 5, showing the close adherence of the heat absorption to first order kinetics.

pepsin in phosphate buffers at 15 and 35°. Figure 5 presents a reproduction of the actual record obtained in a typical run. In Fig. 6 the logarithm of the difference between the final integrator reading and the reading at time t is plotted against the time. It is seen that the heat data conform closely to a first order law up to about 80% completion, the average deviation of the experimental points from the straight line amounting to ± 0.016 revolution, which corresponds to ± 0.0006 joule or ± 5 micro-degrees. Extrapolation to zero time gives a value for the total heat effect, after multiplication by the calibration factor ρ_B , which does not include the relatively large heat of mixing. (During the preheating of calorimeter B, R_7 and R_8 (Fig. 4) had values making ρ_B four times as large as its value during the reaction.) The total heat effect was such that if the continuous compensation method had not been employed, the temperature drop due to the reaction would have been 0.0018°. Essentially the same values for the rate constant and total heat effect are obtained by

application of the Roseveare¹³ method of calculation, in which the "infinity" reading is not utilized.

Data for another run are summarized in Table I. The integrator output readings in the second,

TABLE I
INACTIVATION OF PEPSIN AT 15° IN PHOSPHATE BUFFER,
RUN 63B

Run 63B: 25 ml. of solution containing 0.005 g. of pepsin per ml., pH 6.92, $\Delta t = 15$ min., ionic strength = 0.175, $\rho_B = 0.0372$ joule per rev.

t_2 , min.	Integrator readings corrected for drift			k'	$r_\infty - r_0$	r_∞	r_0
	r_1	r_2	r_3				
19	4.14	6.29	7.30	0.0219	4.96	8.19	3.23
20	4.32	6.39	7.33	.0229	4.94	8.11	3.17
21	4.57	6.47	7.37	.0216	4.86	8.18	3.32
22	4.75	6.59	7.43	.0227	4.88	8.14	3.26
23	4.92	6.66	7.47	.0221	4.88	8.18	3.30
24	5.09	6.72	7.49	.0217	4.84	8.18	3.34
25	5.25	6.79	7.51	.0220	4.80	8.14	3.34
26	5.40	6.87	7.55	.0223	4.81	8.14	3.33
27	5.52	6.93	7.57	.0229	4.87	8.10	3.23
28	5.66	6.98	7.61	.0214	4.79	8.19	3.40
				Mean	0.0222	4.86	3.29
				Av. dev. from mean	$\pm 2.0\%$	$\pm 0.9\%$	± 0.03
						rev.	rev.

$\Delta q = +0.181$ joule

$\Delta H = 12.4$ kcal. per mole (mol. wt. = 36,000)

third and fourth columns correspond to times $t_2 - \Delta t$, t_2 and $t_2 + \Delta t$. The quantities in the last four columns, the rate constant (common logarithms, minutes), the total integrator output change, and the final and initial integrator readings, were calculated by the Roseveare method. The drift corrections included in the integrator output readings were arrived at in the following way: A first approximation to the drift rate was obtained from the original record of the run for times greater than about six half-times, and suitable corrections were applied to the integrator output readings. These were then used to compute k' and $r_\infty - r_0$, from which r_∞ was evaluated by the relation

$$r_\infty = r + (r_\infty - r_0)e^{-2.303k't} \quad (12)$$

The r_∞ values thus obtained for $40 < t < 90$ showed a small additional drift from which final corrections to the integrator output readings were calculated. Integrator readings calculated from the average values of k' , $r_\infty - r_0$ and r_∞ differ from the observed readings by ± 0.017 revolution (± 5 micro-degrees) up to 90% completion.

NEW HAVEN, CONN.

RECEIVED SEPTEMBER 29, 1950

(13) W. E. Roseveare, THIS JOURNAL, 53, 1651 (1931); see also ref. 12.